

8-32 UNC -  $\nabla$  8mm

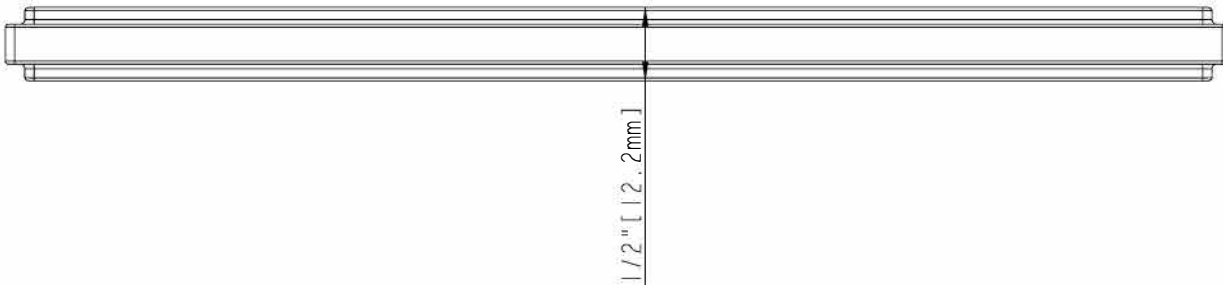
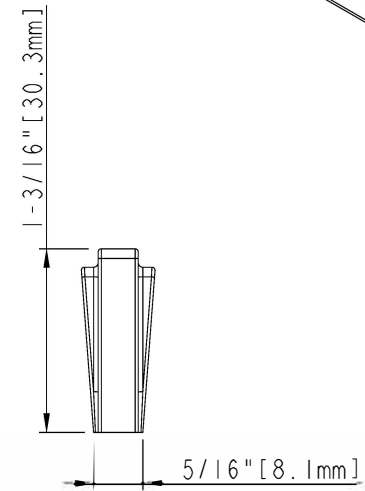
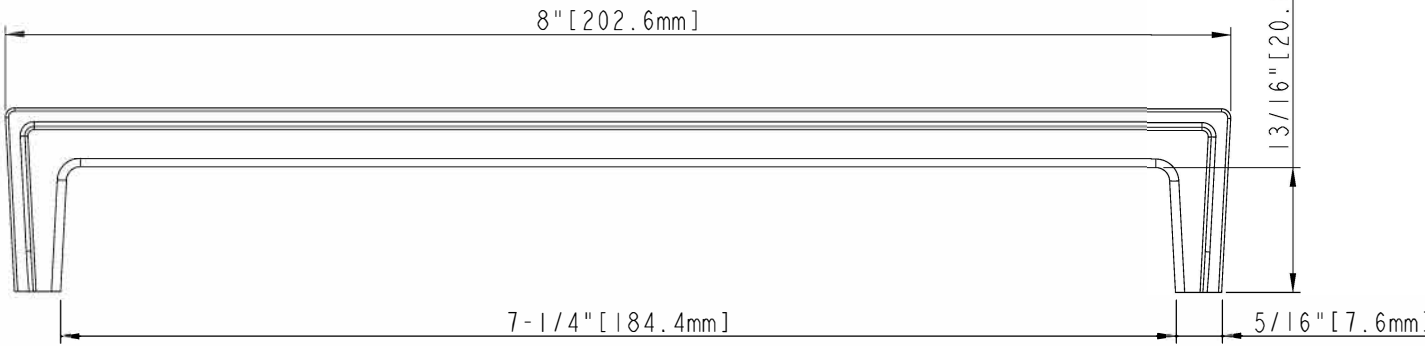
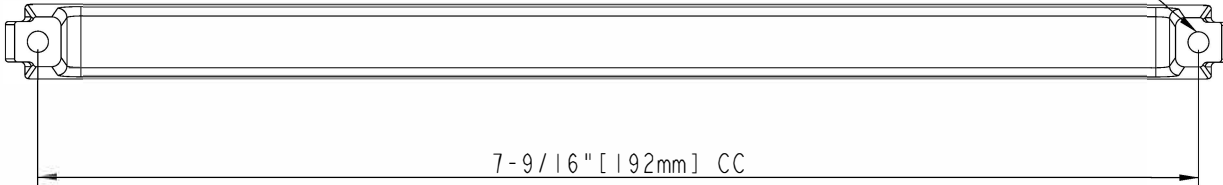

ACCESSORY:  
 SCREW: 8-32x1" 2PCS  
 BREAK AWAY SCREW: 8-32x45 2PCS  
 ALL SCREW MATERIAL: STEEL-SAE1006

	ITEM#:	259-192		MATERIAL:	Zinc
	Finish:			WEIGHT:	144.3g/0.317lbs
PROPRIETARY AND CONFIDENTIAL THE INFORMATION CONTAINED IN THIS DRAWING IS THE SOLE PROPERTY OF HARDWARE RESOURCES INC. ANY REPRODUCTION IN PART OR AS A WHOLE WITHOUT THE WRITTEN PERMISSION OF HARDWARE RESOURCES INC. IS PROHIBITED.	TOLERANCE UNLESS OTHERWISE SPECIFIED:		UNITS:	DRAWN BY:	DATE:
	* $\pm 0.20$ X $\pm 0.10$ XX $\pm 0.05$ ANGULAR: $\pm 0.5^\circ$		SIZE:	APPROVED BY:	DATE:
DO NOT SCALE DRAWING	SHEET:	RELEASE LEVEL:	REVISION: Alexander.W Dec-17-20		